

**Winlet**  
**600**

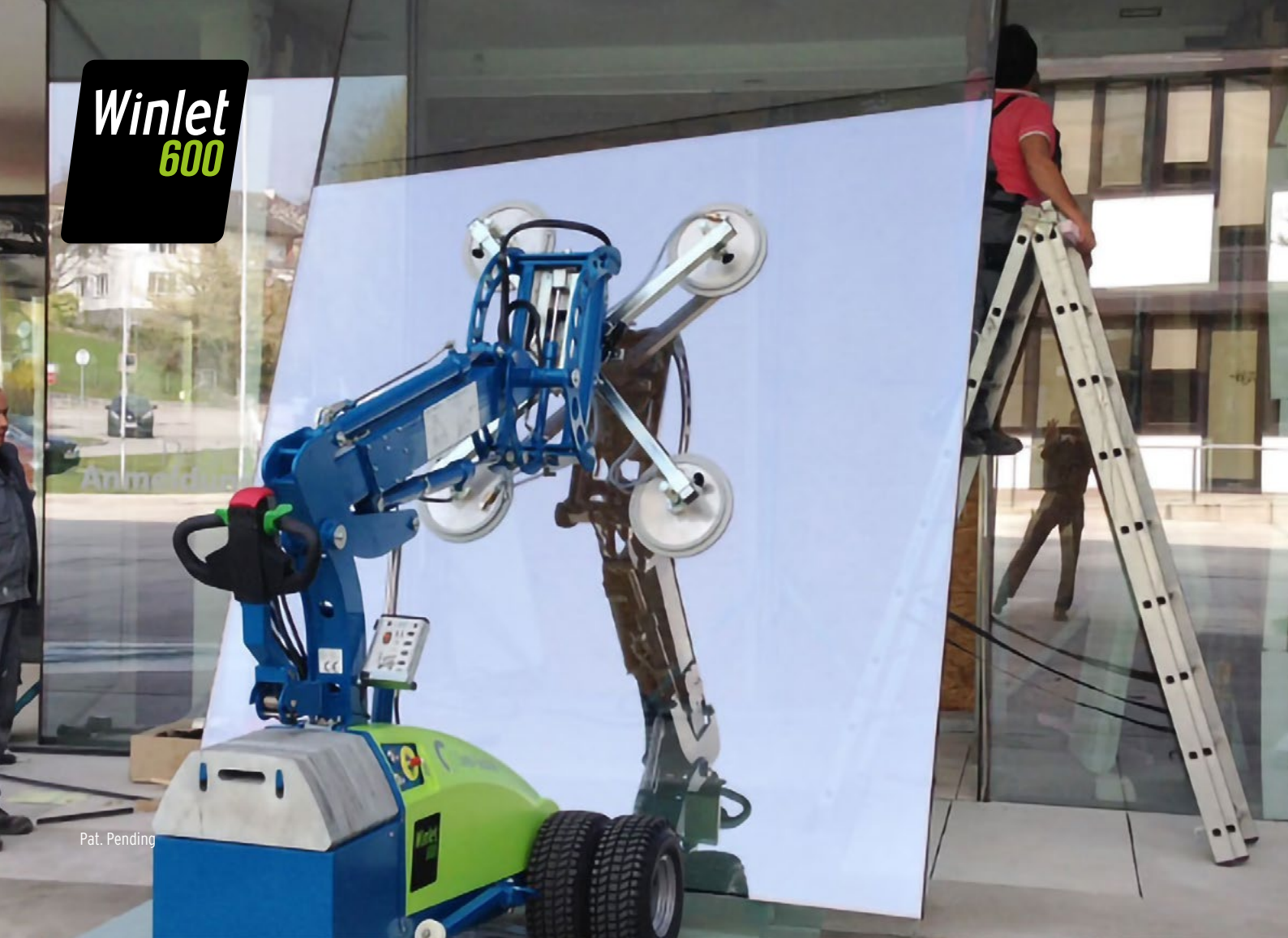

Pat. Pending

## A GOOD WORKING ENVIRONMENT >> LESS DAMAGE TO MATERIALS >> SATISFIED EMPLOYEES >> STRONG BACKS >> FASTER INSTALLATION...

Winlet 600 - a revolutionary new way of installing windows. Using the Winlet 600 window robot, you can quickly and dramatically improve health and safety at work. Window elements weighing up to 600 kg can be lifted, transported and installed easily, without straining the back. The result will show on your bottom line as employees will be able to work more efficiently, avoiding back injuries and sick days, which will result in faster installations without damages to the glass. Finally - a window robot which improves efficiency and meets the increasing requirements from national Occupational Health & Safety Administrations.

[WWW.WINLET.DK](http://WWW.WINLET.DK)



### LIFTS ALL AIR PROOF ITEMS

Winlet 600 can easily be adapted to lift a wide range of materials by changing the suction cups. This makes Winlet 600 ideal also when handling:

GRANITE  
CONCRETE  
PLASTERBORDS  
STEEL PLATES

WOODEN PLATES  
TILES  
FIRE DOORS

## REACH DIAGRAM

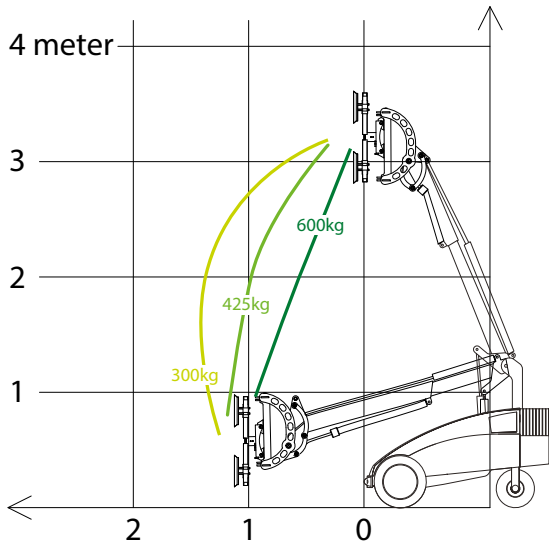

## PICKUP AND PLACE DIAGRAM

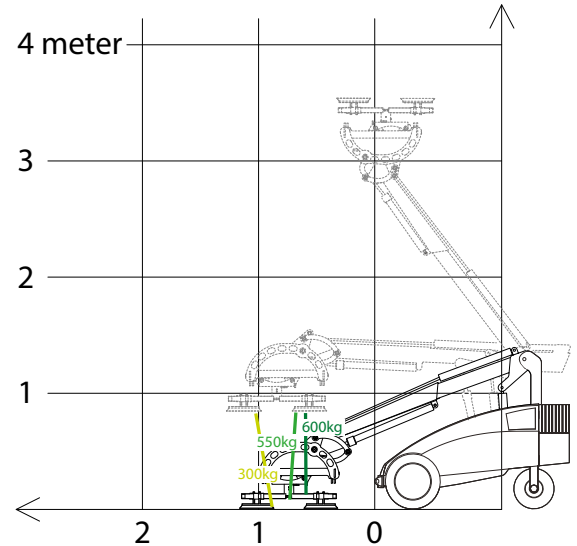

## MAXIMUM CAPACITY - MINIMUM SPACE

Winlet 600 is designed to make installation work easier and faster. No matter if you work indoor or outdoor, Winlet 600 gives you maximum capacity and stability not compromising on the unique and compact design that allows you to go through narrow doorways. Due to the compact design, confined spaces such as elevators and balconies are no problem for Winlet 600. The low point loading of Winlet 600 makes it possible to use it where heavier construction equipment can not be used due to surface pressure.

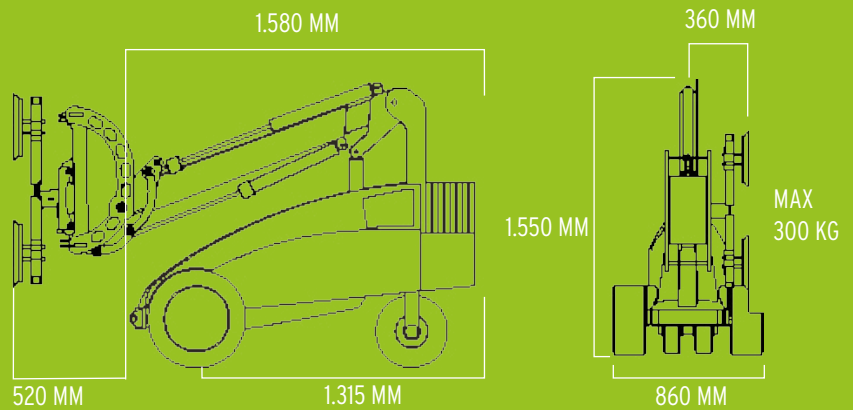

## SPECIFICATIONS

|   |             |
|---|-------------|
| EXTERNAL LENGTH   | 1.580 MM    |
| EXTERNAL WIDTH  | 875 MM      |
| MAX. LIFTING CAPACITY   | 600 KG      |
| MAX. LOAD AT MAX EXTENSION  | 300 KG      |
| MAX. LOAD ON SIDE   | 300 KG      |
| TOTAL WEIGHT <small>excl. counterweights</small>                                | 865 KG      |
| TOTAL WEIGHT <small>incl. counterweights</small>                                | 1.060 KG    |
| MIN. EXTENSION - horizontal arm<br><small>(front bumper to suction cup)</small> | 600 MM      |
| MAX. EXTENSION - horizontal arm<br><small>(front bumper to suction cup)</small> | 1.300 MM    |
| MAX. LIFTING HEIGHT<br><small>(to center of lifting yoke)</small>               | 3.300 MM    |
| SIDE OFFSET   | 90 MM       |
| FINE LIFT ON ARM  | 190 MM      |
| TILT FUNCTION   | 180 DEGREES |
| CONTINUOUS ROTATION   | 360 DEGREES |
| SUCTION CUPS  | 4 X Ø350 MM |
| BATTERIES   | 2 X 95 AH   |

## SUPERIOR USEABILITY AND SAFETY



Multifunction control panel in operator friendly design with integrated buttons. Signal lights and Double action safety keys are both in the standard setup on the Winlet 600.

Winlet 600 is equipped with a state of the art overload monitoring system, which continuously measures the point loading on the steering wheels. If point loading is getting too low the system will automatically cut off the hydraulic functions and only allow hydraulic cylinders to bring the load closer to the machine.

## ACCESSORIES



- **QUICK CONNECTOR** - on suction cups
- **TWIN WHEELS** - for extra rough terrain
- **SUPPORT WHEELS** - for extra stability
- **LIFTING FORK & LIFTING HOOK** - for lifting of pallets or with straps
- **FORKLIFT ADAPTER** - for use in telehandler or forklift
- **LIFTING SLING** - for lifting the Winlet in crane hook
- **RADIO REMOTE CONTROL**

Dealer:

GMV A/S (SOUTH)  
INDUSTRI PARKEN 1  
DK - 7182 BREDSTEN

GMV A/S (NORTH)  
INDUSTRIVEJ 10  
DK - 7620 LEMVIG

TEL +45 7573 8247  
CVR DK 21801283  
WWW.GMVAS.DK  
WWW.WINLET.DK  
WWW.ERGOMOVER.DK

**GMV**  
Cranes and Handling