

Winlet
575



Pat. Pending

A GOOD WORKING ENVIRONMENT » LESS DAMAGE TO MATERIALS » SATISFIED EMPLOYEES » STRONG BACKS » FASTER INSTALLATION...

Winlet 575 - a revolutionary new way of installing windows. Using the Winlet 575 window robot, you can quickly and dramatically improve health and safety at work. Window elements weighing up to 575 kg can be lifted, transported and installed easily, without straining the back. The result will show on your bottom line, because your employees will be happier and more efficient, damage will be reduced and installation will be speeded up. Finally - a window robot which meets H&S requirements and improves efficiency.

WWW.WINLET.DK



LIFTS ALL AIR PROOF ITEMS

Winlet 575 can easily be adapted to lift a wide range of materials by changing the suction cups. This makes Winlet 575 ideal when handling:

GRANITE
CONCRETE
PLASTERBORDS
STEEL PLATES

WOODEN PLATES
TILES
FIRE DOORS

REACH DIAGRAM

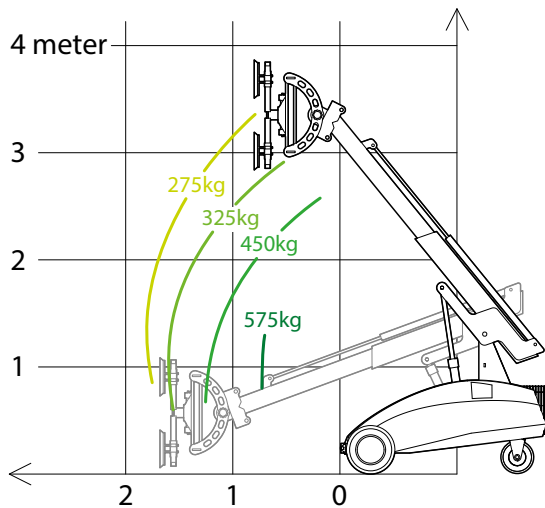

PICKUP AND PLACE DIAGRAM

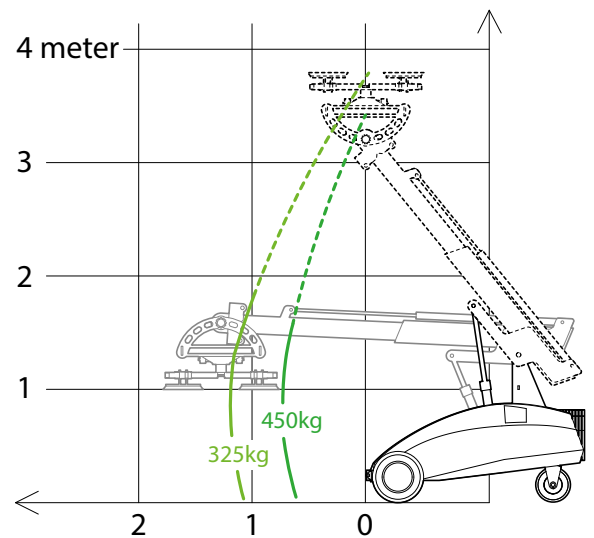

MAXIMUM CAPACITY - MINIMUM SPACE

Winlet 575 combines superior lifting capacity and reach with a unique and compact design. Only with Winlet 575, you can handle heavy elements up to 575 kg bringing it through rough terrain and narrow doorways. Due to the compact design, confined spaces such as elevators and balconies are no problem for Winlet 575. The low weight of Winlet 575 makes it possible to use it where heavier construction equipment cannot be used due to surface pressure.

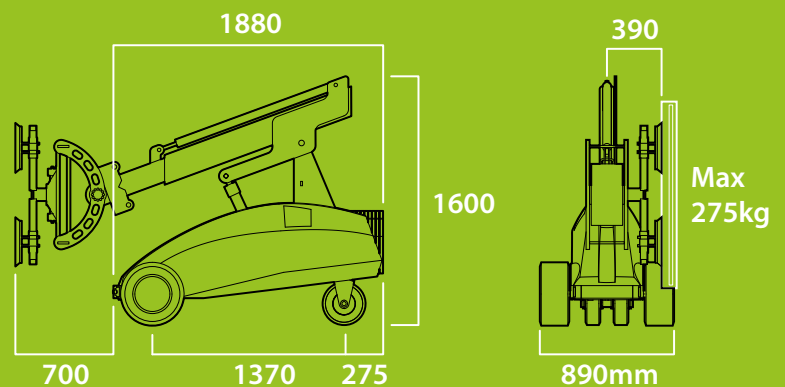

SPECIFICATIONS

EXTERNAL LENGTH	1.880 MM
EXTERNAL WIDTH	890 MM
MAX. LIFTING CAPACITY	575 KG
MAX. LOAD AT MAX EXTENSION	275 KG
MAXIMUM CAPACITY ON SIDE	275 KG
TOTAL WEIGHT excl. counterweights	1.025 KG
TOTAL WEIGHT incl. counterweights	1.300 KG
MIN. EXTENSION (Front bumper to suction cup)	700 MM
MAX. EXTENSION (Front bumper to suction cup)	1.800 MM
MAX. LIFTING HEIGHT (to center of lifting yoke)	3.600 MM
HYDRAULIC SIDE OFFSET	75 MM
FINE LIFT ON ARM	190 MM
TILT FUNCTION	180 DEGREES
HYDRAULIC ROTATION	180 DEGREES
SUCTION CUPS	4 X Ø350 MM
BATTERIES	2 X 150 AH

ACCESSORIES



- **TWIN WHEELS** - for extra rough terrain
- **SUPPORT WHEELS** - for extra stability
- **LIFTING FORK & LIFTING HOOK** - for lifting of pallets or with straps
- **LIFTING SLING** - for lifting the Winlet in crane hook
- **SHUT-OFF VALVES** - on suction cup
- **QUICK CONNECTORS** - on suction cups or main supply
- **EXTENSION OF THE BEAMS** - customized cross- and main beams
- **RADIO REMOTE CONTROL**

SUPERIOR USEABILITY



Multifunction control panel in operatorfriendly design with integrated buttons and signal lights, Double action safety keys and Gyro functionality are both in the standard setup on the Winlet 575.

Dealer:

GMV A/S (SOUTH)
INDUSTRI-PARKEN 1
DK - 7182 BREDSTEN

GMV A/S (NORTH)
INDUSTRIVEJ 10
DK - 7620 LEMVIG

TEL +45 7573 8247
CVR DK 21801283
WWW.GMVAS.DK
WWW.WINLET.DK
WWW.ERGOMOVER.DK

GMV
Cranes and Handling